

MSA 771, MSA 871

MSA 771



MSA 871



Abmessungen, Anbautoleranzen MSA 771:

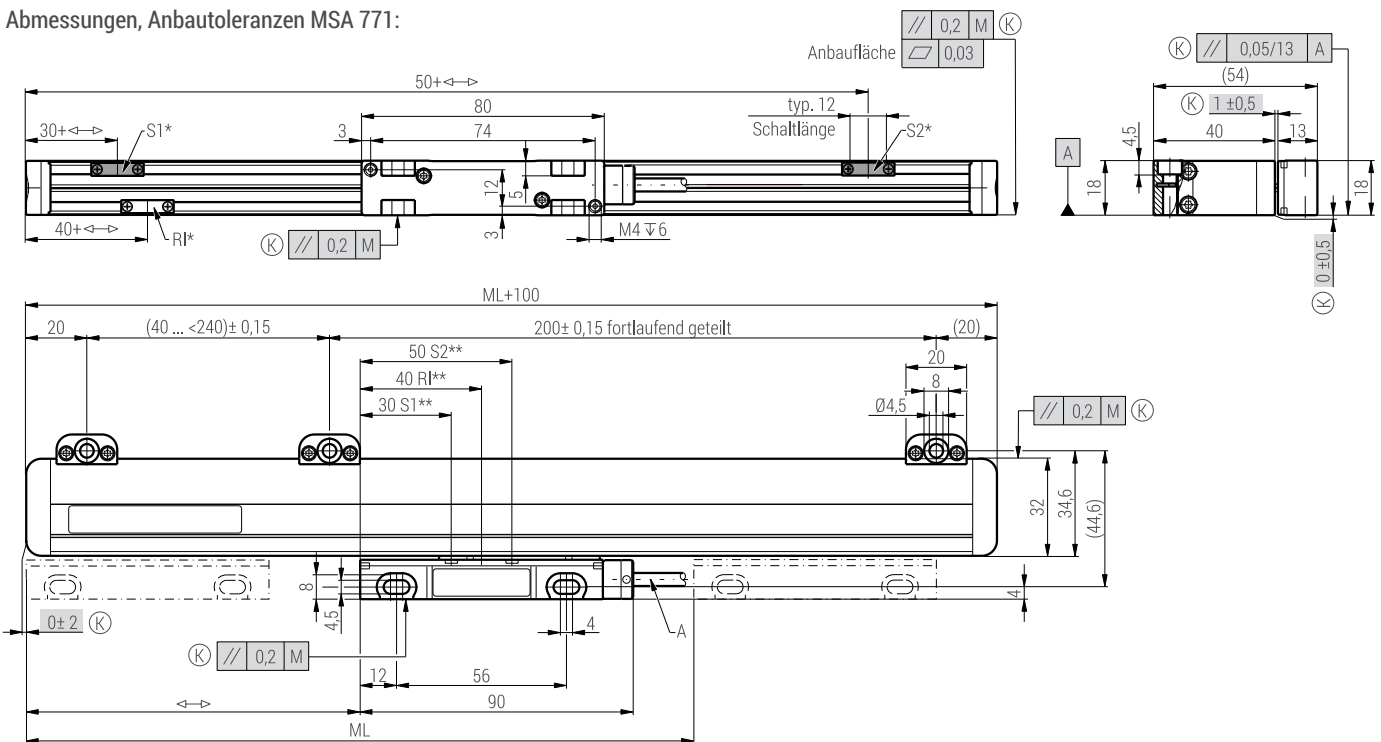

Abmessungen, Anbautoleranzen MSA 871:

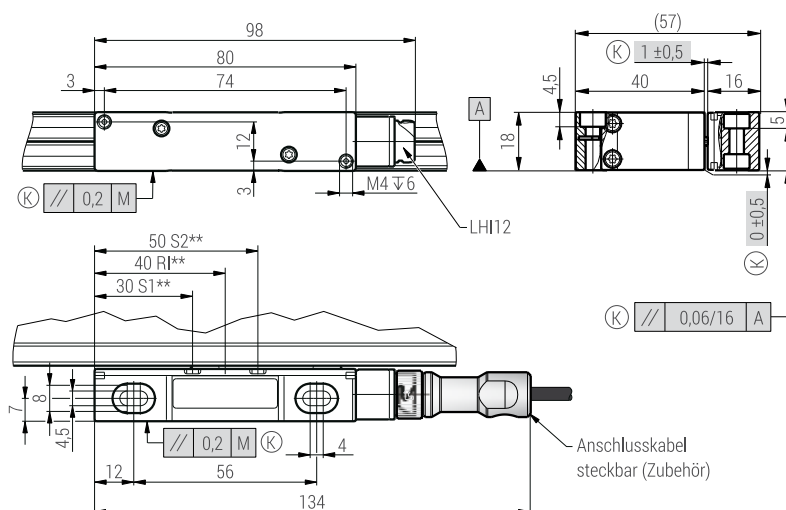

M = Maschinenführung

ML = Messlänge

\leftrightarrow = $0 \dots ML$

A = Anschlusskabel

LHI12 = Stecker

(K) = kundenseitige Anbaumaß

OPTIONEN:

S1, S2 = Schaltsignale

RI = wählbare Referenzmarke

* = Schaltmagnet

** = Sensorposition