

# MSA 730, MSA 830

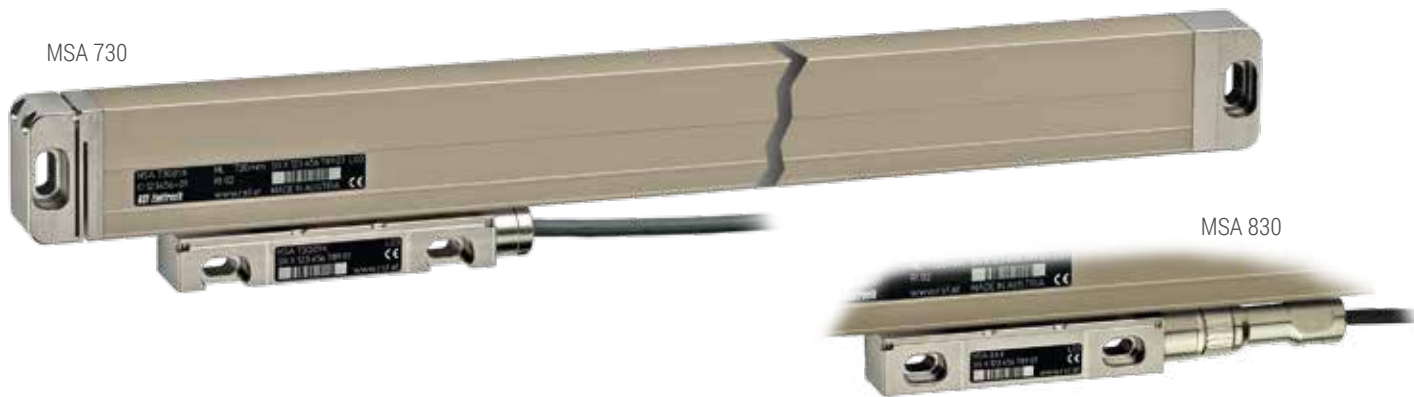

Dimensions, mounting tolerances MSA 730:

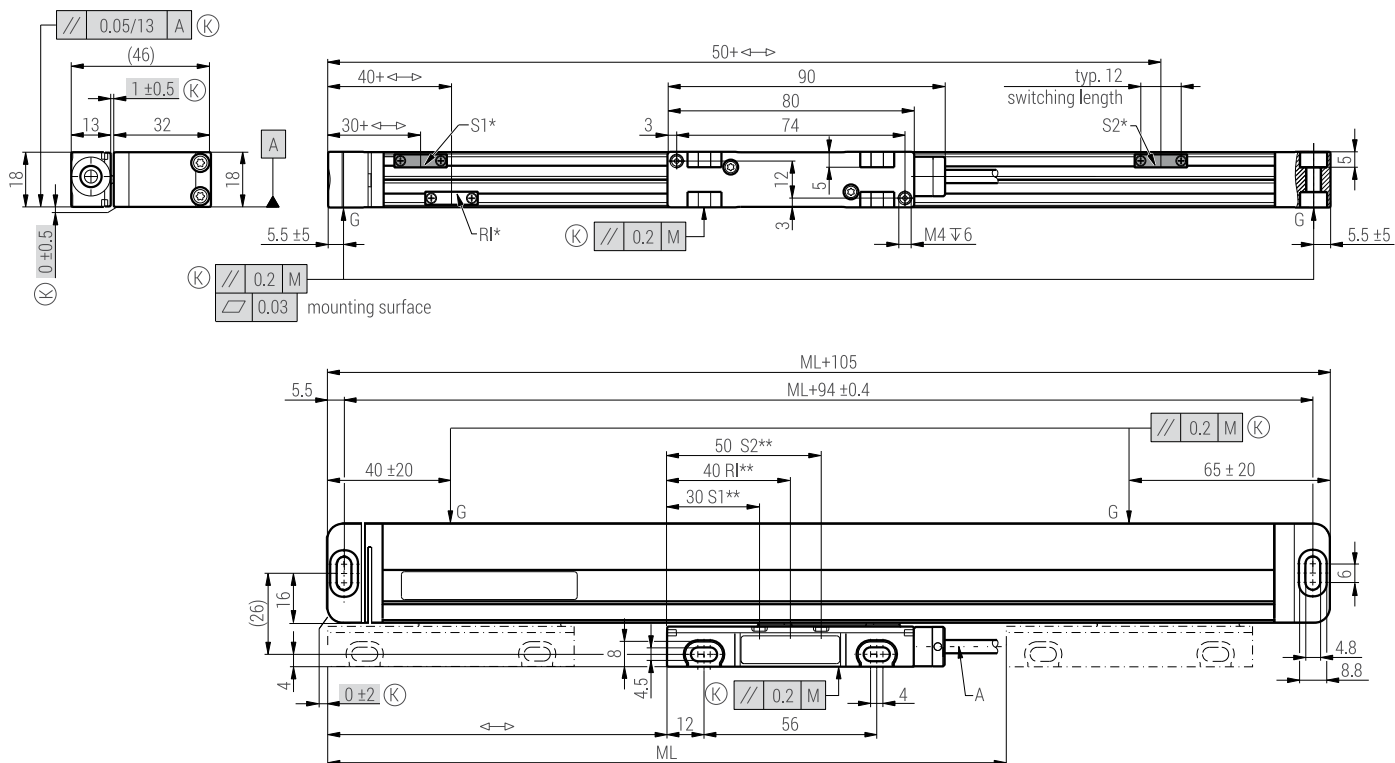

Dimensions, mounting tolerances MSA 830:

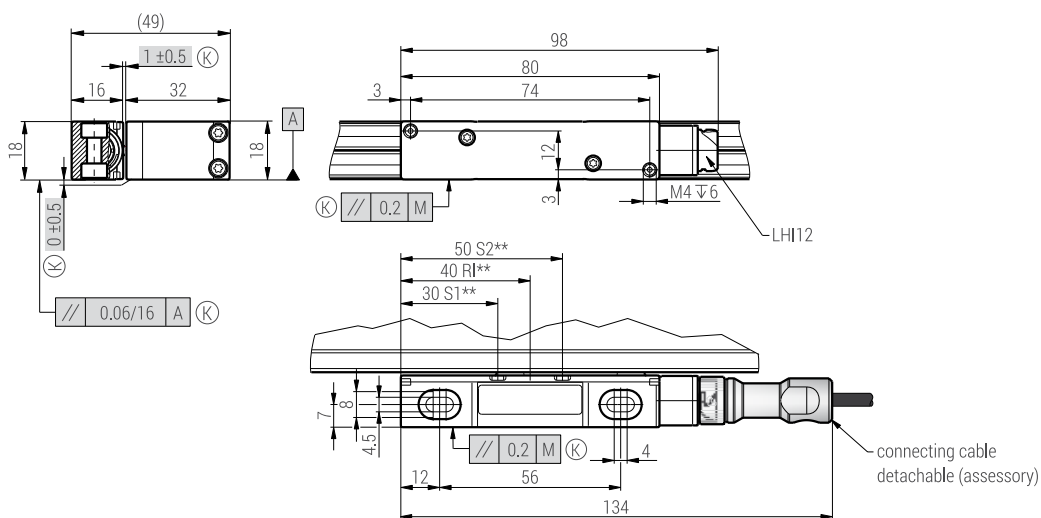

- M = machine guideway
- ML = measuring length
- G = gauging points
- ↔ = 0 ... ML
- A = cable

LHI12 = male connector

(K) = required mating dimensions

OPTIONAL:

- S1, S2 = switch signals
- RI = selectable reference mark
- \* = actuator magnet
- \*\* = sensor position

connecting cable detachable (accessory)