

MSA 431, MSA 531

MSA 431

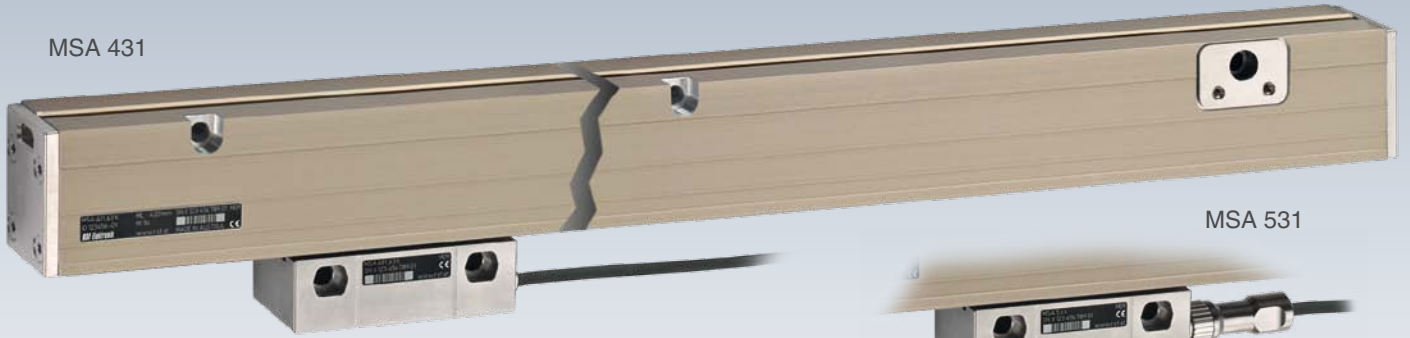

MSA 531



Dimensions, mounting tolerances MSA 431:

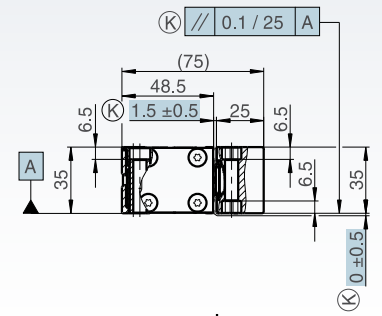
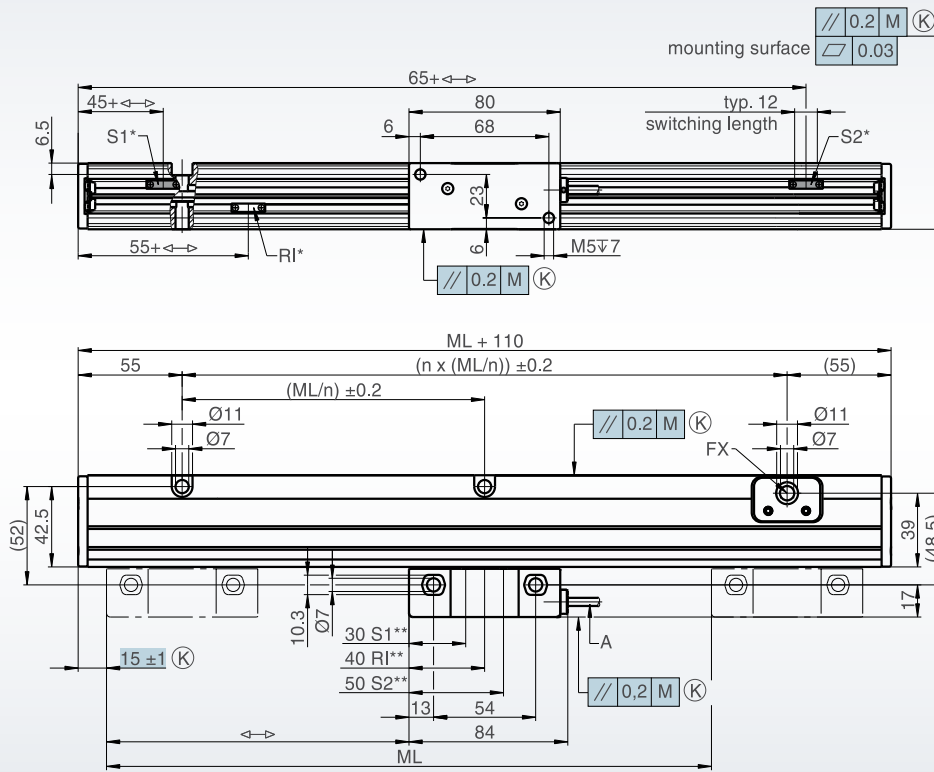

| measuring length | n |
|------------------|----|
| ML > 56 - 600 | 2 |
| ML > 600 - 1200 | 4 |
| ML > 1200 - 1800 | 6 |
| ML > 1800 - 2400 | 8 |
| ML > 2400 - 3000 | 10 |
| ML > 3000 - 3040 | 12 |

- M = machine guideway
- ML = measuring length
- \leftrightarrow = 0 ... ML
- A = cable
- (K) = required mating dimensions
- FX = fixed-point

- optional:
- P = air inlet M5
 - S1, S2 = switch signals
 - RI = selectable reference mark
 - * = actuator magnet
 - ** = sensor position

option P: air inlet scale
left or right side mountable

accessory: air inlet reading head
(ID 1079056-01)

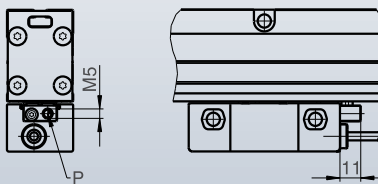
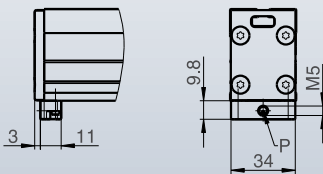

Dimensions MSA 531:

