

MSA 411, MSA 511

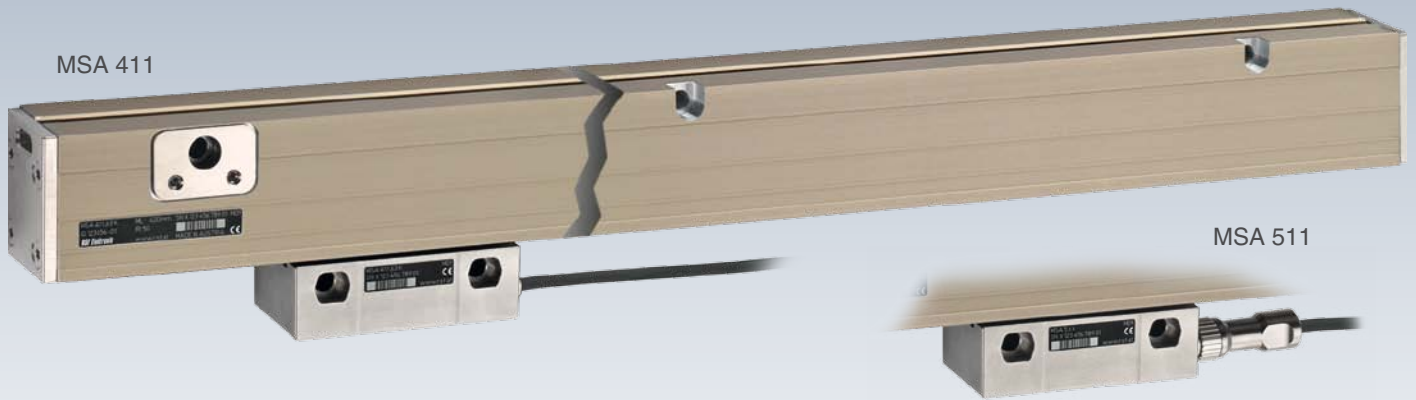

Dimensions, mounting tolerances MSA 411:

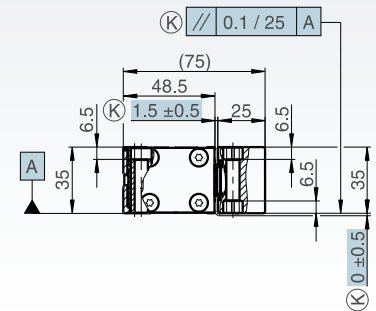
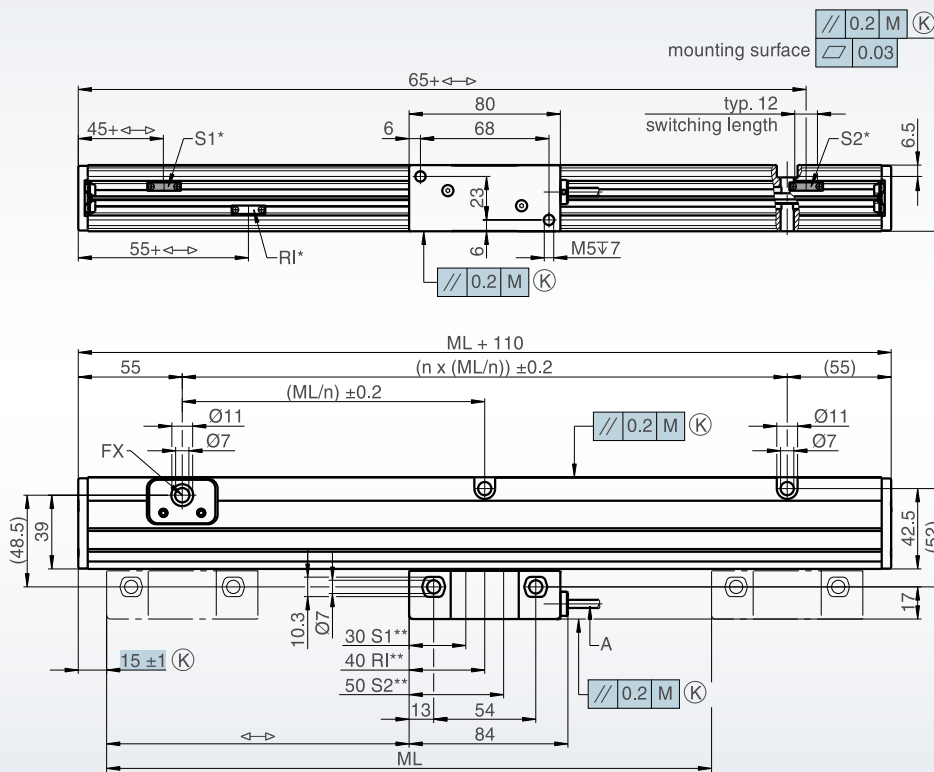

measuring length	n
ML > 56 - 600	2
ML > 600 - 1200	4
ML > 1200 - 1800	6
ML > 1800 - 2400	8
ML > 2400 - 3000	10
ML > 3000 - 3040	12

M = machine guideway
 ML = measuring length
 \leftrightarrow = 0 ... ML
 A = cable

(K) = required mating dimensions

FX = fixed-point

optional:

P = air inlet M5

S1, S2 = switch signals

RI = selectable reference mark

* = actuator magnet

** = sensor position

option P: air inlet scale
 left or right side mountable

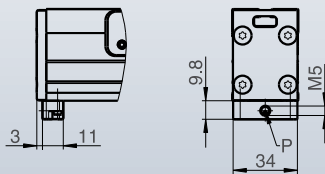

accessory: air inlet reading head
 (ID 1079056-01)

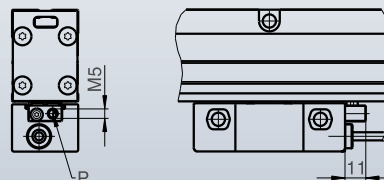

Dimensions MSA 511:

