



HEIDENHAIN

Montageanleitung
Mounting Instructions
Instructions de montage
Istruzioni di montaggio
Instrucciones de montaje

TT 449

5/2009

Warnhinweise
Warnings
Recommandations
Avvertenze
Advertencias

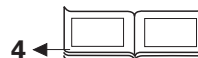

Technische Kennwerte
Specifications
Caractéristiques techniques
Dati tecnici
Datos técnicos



Lieferumfang
Items Supplied
Contenu de la fourniture
Standard di forniture
Elementos suministrados



Abmessungen
Dimensions
Dimensions
Dimensioni
Dimensiones



Hinweise zur Montage / Montage
Mounting Procedure / Mounting
Procédure de montage / Montage
Avvertenze per il montaggio / Montaggio
Indicaciones para el montaje / Montaje



Verbindungsstift/Antastelement wechseln
Exchanging the Connection Pin/Probe Contact
Changer la tige de liaison/l'élément de palpge
Sostituire spina di collegament/elemento di tastatura
Cambiar el vástago de unión/elemento de palpación



Batterienwechsel
Battery Change
Changement d'accu
Sostituzione batteria
Cambio de batería



Zentrieren / Signalfolge
Centering / Signal sequence
Centrage / Train du signal
Centratura / Sequenza segnali
Centraje / sucesión de señales



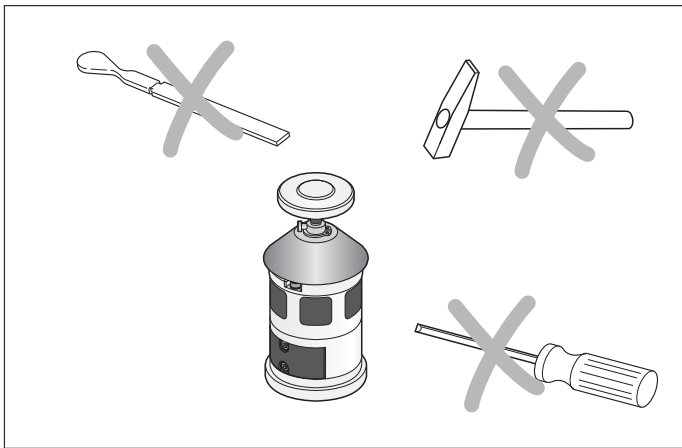

Maße in mm
Dimensions in mm
Cotes en mm
Dimensioni in mm
Dimensiones en mm



Achtung: Die Montage und Inbetriebnahme ist von einer Fachkraft für Elektrik und Feinmechanik unter Beachtung der örtlichen Sicherheitsvorschriften vorzunehmen.

Note: *Mounting and commissioning is to be conducted by a specialist in electrical equipment and precision mechanics under compliance with local safety regulations.*

Attention: Le montage et la mise en service doivent être réalisés par une personne qualifiée en électricité et mécanique de précision dans le respect des règles de sécurité locales.

Attenzione: *il montaggio e la messa in funzione devono essere eseguiti da tecnici specialisti elettricisti e in meccanica di precisione nel rispetto delle norme di sicurezza locali.*

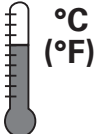

Atención: El montaje y la puesta en marcha deben ser realizados por un especialista en electricidad y mecánica de precisión, observando las prescripciones locales de seguridad.

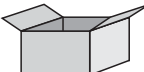

°C
(°F)

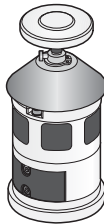

-20 ... 70 °C
(- 4 ... 158 °F)



IP 67
EN 60 529

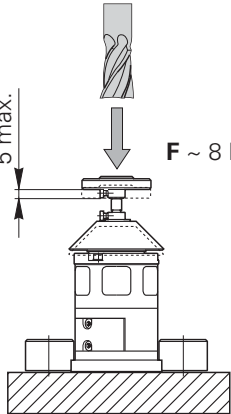

5 max.

$F \sim 8 \text{ N}$

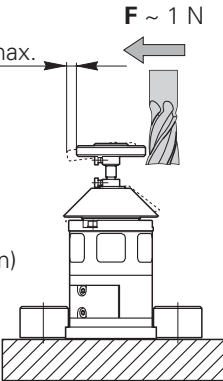

5 max.

$F \sim 1 \text{ N}$

$2 \sigma \leq 1 \mu\text{m}$
($v = 0.4 \text{ m/min}$)

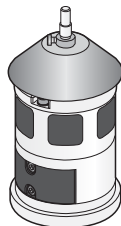
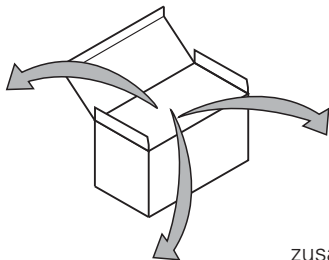
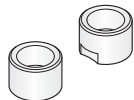

zusätzlicher Verbindungsstift (mit Sollbruchstelle ID 559 758-01)
Additional connection pin (rated break point ID 559 758-01)
 tige de liaison supplémentaire (avec point de rupture ID 559 758-01)
spine di collegamento aggiuntive (con punta di rottura nominale ID 559 758-01)
 vástago de unión adicional (con fusible mecánico ID 559 758-01)

Optionen · Options · Options · Opzioni · Opciones

Antastelement
Probe contact
 Elément de palpéage
Elemento di tastatura
 Elemento de palpación



ID 574 752-01



ID 527 801-01

Ersatzteilkit Stift
Spare parts kit for connection pin
 Kit de rechange tige
Kit di sostituzione spine
 Kit de recambio del vástago



ID 559 758-01

Montagesockel
Connection fixture
 Socle de montage
Dima di montaggio
 Zócalo de montaje

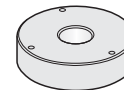

ID 651 586-01

Separat bestellen
Order separately
Commander Séparément
Ordinare separatamente
Pedir por separado

SE 642

ID 652 792-xx



ID 370 827-01

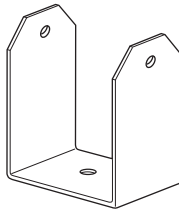

Halter für SE 642
Holder for SE 642
Attache pour SE 642
Supporto per SE 642
Saporte para SE 642

UTI 240

ID 658 883-01

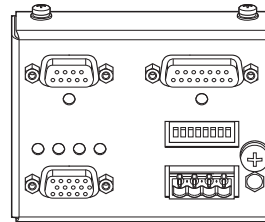

Interface-Elektronik für iTNC 530
Interface electronics for iTNC 530
Electronique d'interface pour iTNC 530
Elettronica di interfaccia per iTNC 530
Electrónica de interfaz para el iTNC 530

Abmessungen · Dimensions · Dimensions · Dimensioni · Dimensiones

mm



Tolerancing ISO 8015

ISO 2768 - m H

< 6 mm: ±0.2 mm

Befestigung mit Spannpratzen

Mounting with fixing clamps

Fixation avec griffes de serrage

Fissaggio con graffette

Fijación con garras excéntricas

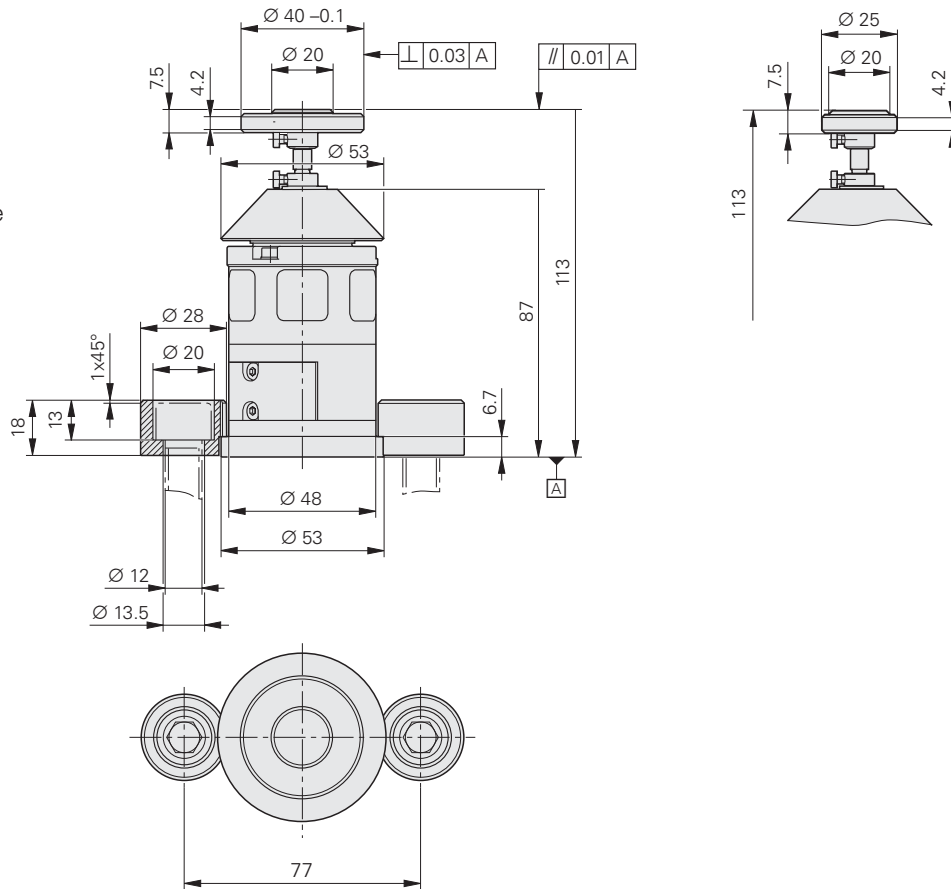

mm



Tolerancing ISO 8015

ISO 2768 - m H

< 6 mm: ± 0.2 mm

Befestigung auf Montagesockel (Zubehör)

Mounting on connection fixture (accessory)

Fixation avec socle de montage (accessoire)

Fissaggio della dima di montaggio (accessorio)

Fijación sobre zócalo de montaje (accesorio)

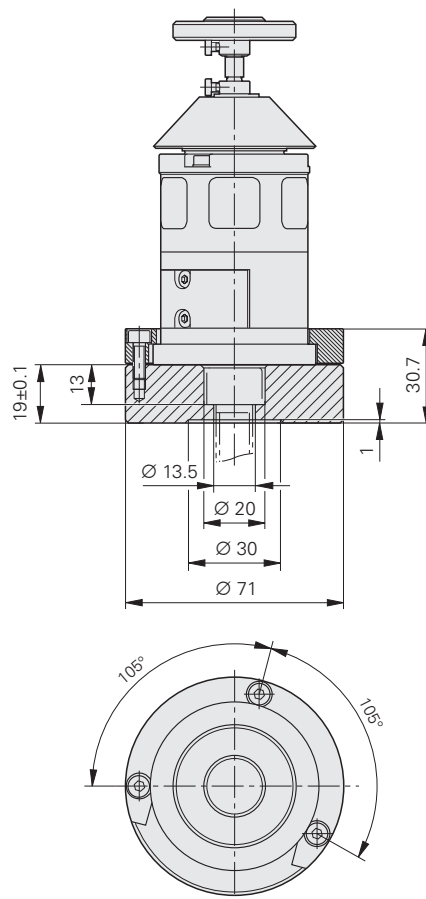

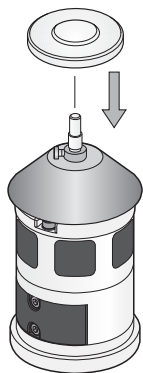

Achtung: Krafteinwirkung kann Verbindungsstift zerstören

Caution: Too much force can destroy the connection pin

Attention: La force exercée peut détruire la tige de liaison

Attenzione: una forza eccessiva potrebbe rompere lo spine di collegamento

Atención: La aplicación de fuerza puede dañar el vástago de unión

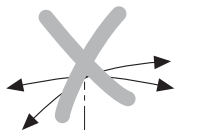

SW2 
M_d = 1 Nm

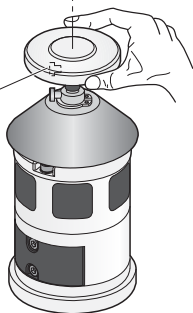

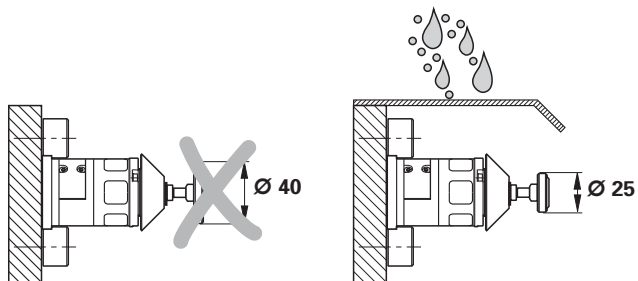

2x
M12 ISO 4762
 $M_d = 75 \text{ Nm}$

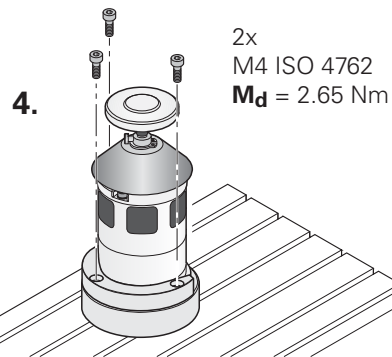
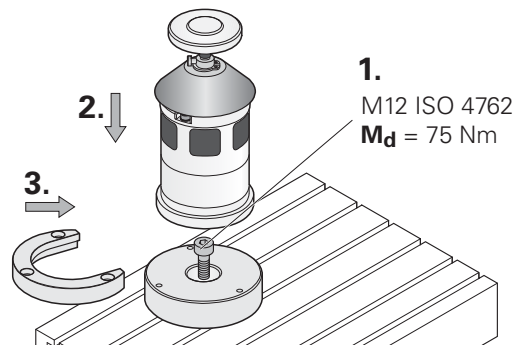
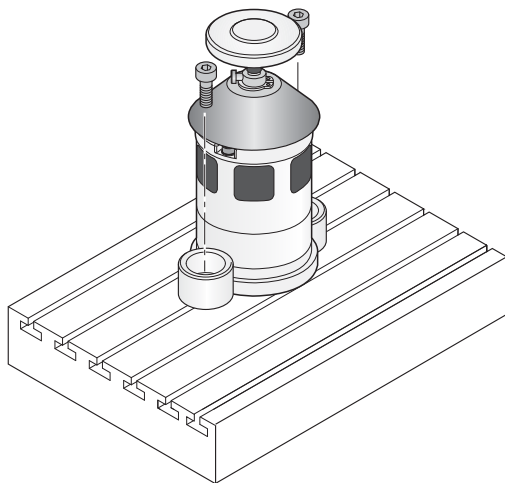

1.

1x bzw. 2x lösen

Loosen 1 or 2 screw(s)

Dévisser 1x ou 2x

1x o 2x allentare

Desatornillar 1x o 2x

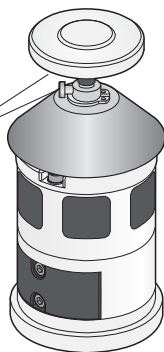
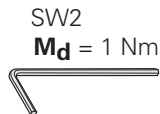

2.

Antastelement entnehmen

Remove the probe contact

Retirer l'élément de palpéage

sfilare l'elemento di tastatura

Retirar el elemento de palpación

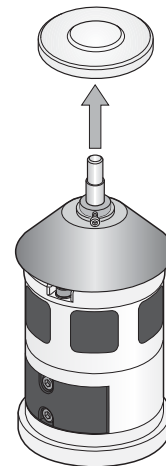

SW2
 $M_d = 1 \text{ Nm}$

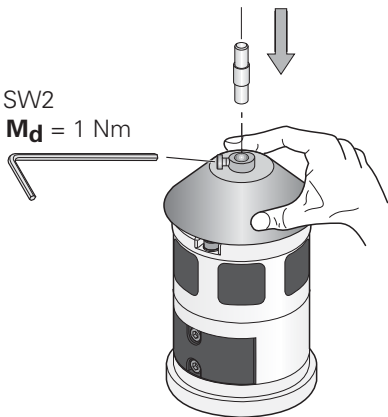

3.

Verbindungstift auswechseln

Exchange the connection pin

Changer la tige de liaison

sostituire la spina di collegamento

Cambiar el vástago de unión

neue Schraube verwenden (Lieferumfang)

Use a new screw (included in items supplied)

Utiliser une nouvelle vis (dans la fourniture)

utilizzare viti nuove (nello standard di fornitura)

utilizar nuevo tornillo (contenido en elementos suministrados)

4.

Antastelement befestigen
Secure the probe contact
Fixer l'élément de palpation
Fissare l'elemento di tastatura
Fijar el elemento de palpación

neue Schraube verwenden (Lieferumfang)
Use a new screw (included in items supplied)
Utiliser une nouvelle vis (dans la fourniture)
utilizzare viti nuove (nello standard di fornitura)
utilizar nuevo tornillo (contenido en elementos suministrados)

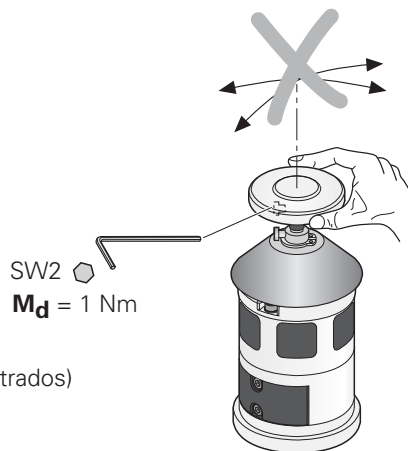

5.

Tastsystem neu kalibrieren
Recalibrate the touch probe
Réétalonner le palpeur
Ricalibrare il sistema di tastatura
Volver a calibrar el sistema de palpación



Achtung: Krafteinwirkung kann Verbindungsstift zerstören

Caution: Too much force can destroy the connection pin

Attention: La force exercée peut détruire la tige de liaison

Attenzione: una forza eccessiva potrebbero rompere le spine di collegamento

Atención: La aplicación de fuerza puede dañar el vástago de unión

öffnen
open
ouvrir
aprire
abrir

1.

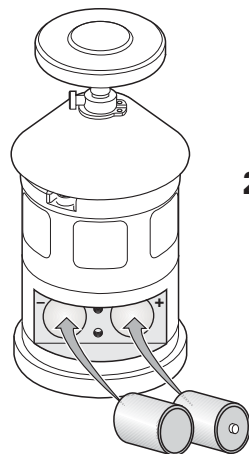

2.

ID 376 021-02

LITHIUM
Size 2/3AA
3.6 V

nicht aufladbar, im Lieferumfang enthalten
non-rechargeable, included in delivery
non chargeable, contenu dans la fourniture
non ricaricabile, standard di fornitura
no recargable, elementos suministrados

schließen
close
fermer
chiudere
cerrar

2x

$M_d = 1.5 \pm 0.2 \text{ Nm}$

3.

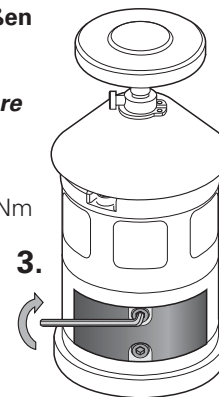

Alkaline-Batterien oder NiMH-Akkus mit 1–4 V sind ebenfalls verwendbar.
Alkaline batteries or NiMH accumulators with 1 to 4 volts can also be used.
Des piles alcalines ou accus NiMH à 1–4 V peuvent être également utilisés.
É possibile utilizzare sia le batterie alcaline sia accumulatori NiMH con 1-4 V.
También se pueden emplear baterías alcalinas o recargables NiMH de 1-4 V.

Ⓐ

Ⓑ

Bei Batterien des Types Lady, LR1 benutzen Sie beiliegende Adapter.
For N (LR1/AM-5) batteries, please use the enclosed adapters.
Pour les piles de type Lady, LR1, utilisez les adaptateurs joints.
Con batterie del tipo Lady, LR1 utilizzare l'adattatore allegato.
Con baterías del tipo Lady LR1, utilizar el adaptador adjunto.

ID 589 051-01

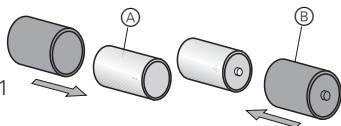

Elektronisch
Electronic
électronique
elettronico
electrónico

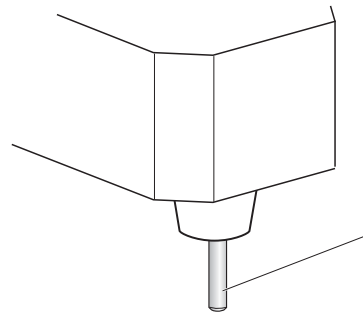

Passtift (kundenseitig)
Passtift (kundenseitig)
Goupille (côté client)
Spina calibrata (cliente)
Vástago de alineamiento (lado cliente)

durch NC - Kalibrierprogramm
With NC calibration program
par programme d'étalonnage CN
tramite programmazione di calibrazione NC
mediante programa de calibración NC

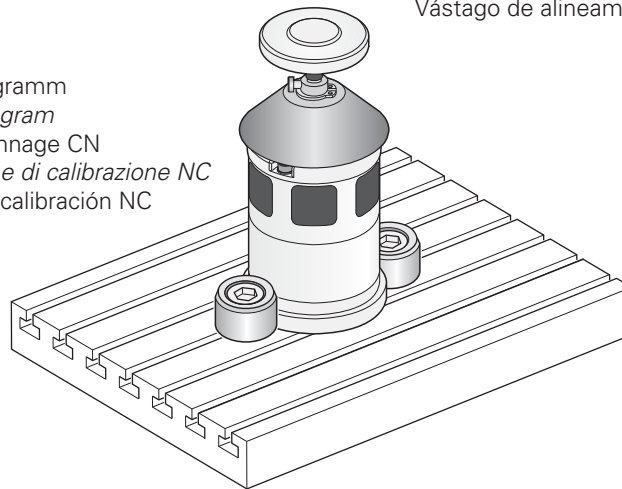

Signalfolge · *Signal sequence* · Train du signal · *Sequenza segnali* · sucesión de señales

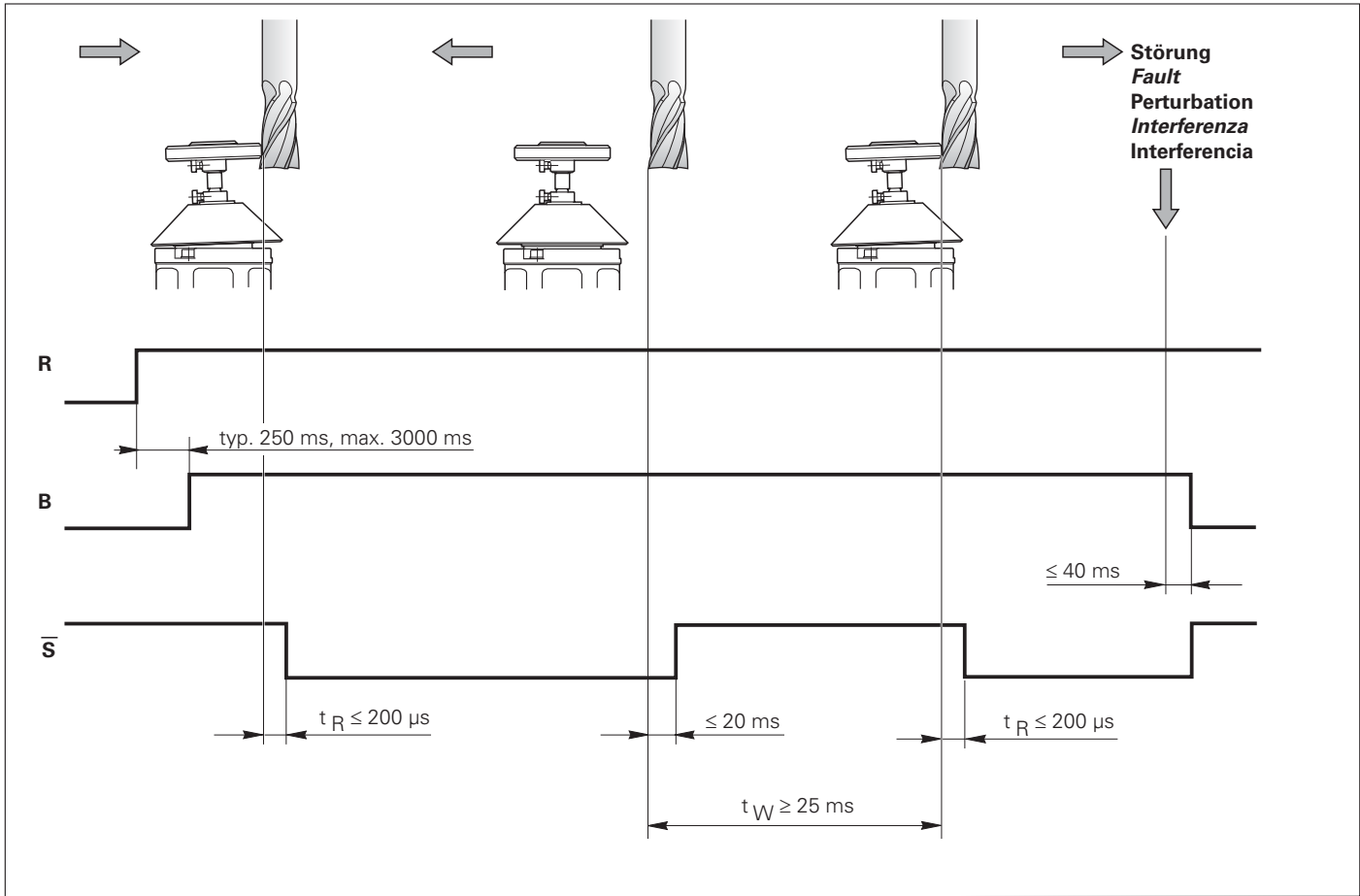

HEIDENHAIN

DR. JOHANNES HEIDENHAIN GmbH

Dr.-Johannes-Heidenhain-Straße 5

83301 Traunreut, Germany

☎ +49 (8669) 31-0

FAX +49 (8669) 5061

E-mail: info@heidenhain.de

Technical support FAX +49 (8669) 32-1000

Measuring systems ☎ +49 (8669) 31-3104

E-mail: service.ms-support@heidenhain.de

TNC support ☎ +49 (8669) 31-3101

E-mail: service.nc-support@heidenhain.de

NC programming ☎ +49 (8669) 31-3103

E-mail: service.nc-pgm@heidenhain.de

PLC programming ☎ +49 (8669) 31-3102

E-mail: service.plc@heidenhain.de

Lathe controls ☎ +49 (8669) 31-3105

E-mail: service.lathe-support@heidenhain.de

www.heidenhain.de

